

# Driving Skills Test Study Guide

# Table of Contents

Purpose of This Study Guide .....	3
Third-Party Driving Skills Test Administration.....	3
Third-Party Testing Organization Business Requirements .....	6
Reporting Improper, Illegal, or Fraudulent Testing Activities.....	6
Foreign Language Interpreters .....	7
Interpreters for the Deaf and Hard of Hearing.....	7
Facilitators.....	7
Requirements for Taking the Driving Skills Test.....	8
Scheduling a Driving Skills Test.....	9
What to Take to the Third-Party Testing Organization .....	10
Tests Terminated Due to Defective Equipment .....	10
Safety Inspection.....	11
Other Automatic Failures.....	11
Dangerously Inexperienced Drivers.....	12
Components of the Driving Skills Test .....	13
Basic Control Skills Test Requirements .....	13
Figure 1: Forward Stop Line.....	14
Figure 2: Curved Path Backing (Sight-Side) .....	15
Figure 3: Curved Path Backing (Blind-Side).....	16
The On-the-Road Test.....	16

Driving Skills Test Requirements .....	17
Driving Skills Test Scoring Standards .....	17
Turns .....	17
Stop Intersections.....	19
Through Intersections (Do Not Require Stopping).....	20
Expressway or Rural Highway .....	20
Urban and Residential Areas .....	22
Curves .....	23
Railroad Crossings.....	23
Turn Fan (or Radio) On/Off.....	24
Crash Avoidance (Simulated Head-On Collision).....	24
General Driving Habits .....	24
Search.....	25
Speed and Brake Control .....	25
Direction and Space Control.....	26
Steering Control.....	27
Timing.....	27
Miscellaneous Traffic Violations .....	28
Completion of the Driving Skills Test .....	28
Student Driving Experience Log.....	29

---

---

## Driving Skills Test Study Guide

---

---

### Purpose of This Study Guide

As a new driver, you must pass the driving skills test before you are eligible to receive a Michigan driver's license from the Secretary of State office. This study guide will prepare you for the driving skills test you are required to take.

### Third-Party Driving Skills Test Administration

In Michigan, all driver testing is mandated by state and federal laws. The Department of State administers driver knowledge (written) tests only through a branch office. Driving skills testing services are provided only through a privatized, third-party testing program. This program utilizes a statewide network of public and private organizations authorized by the Department to conduct the driving skills tests. The Department is committed to assuring that driving tests (both written and skills) are given by qualified persons trained to administer the tests in a fair, honest, and reliable manner.

You should familiarize yourself with the procedures and requirements for your driving skills test. While the *Driving Skills Test Study Guide* provides some information about all driving tests, its primary focus is on the auto driving skills test. For more information on skills tests required for a motorcycle endorsement or a commercial driver license, obtain one of the following guides from a Secretary of State branch office or [www.Michigan.gov/sos](http://www.Michigan.gov/sos).

- ***Motorcycle Operator Manual*** (SOS-116)
- ***Commercial Driver License Manual*** (TS-004)

Drivers should question any driving skills test that does not include all the test components as described in the appropriate study guide. The following table illustrates the required driving skills test components and the approximate time needed to complete each.

The times are estimates based on an average length driving route, good weather conditions, light traffic and a well-prepared driver. Skills tests must include all the segments listed below. A test may take more time than shown in this table, but should not take significantly less time.

TEST TYPE	VEHICLE INSPECTION	BASIC CONTROL SKILLS	ON-STREET DRIVING TEST	TOTAL TIME
Automobile	5 minutes (not scored)	10 minutes (scored)	30 minutes-1 hour (scored)	45 min.-1 hr., 15 min.
Motorcycle	5 minutes (not scored)	10-20 minutes (scored)	N/A	15-25 minutes
CDL Group A	1-2 hours (scored)	20-30 minutes (scored)	40 minutes-1 hour (scored)	2 hours-3 hrs., 30 min.
CDL Group B	30 minutes-1 hour (scored)	20-30 minutes (scored)	40 minutes-1 hour (scored)	1 hr., 30 min.-2 hrs., 30 min.
CDL Group C	20-30 minutes (scored)	20-30 minutes (scored)	40 minutes-1 hour (scored)	1 hr., 20 min.-2 hours

**During the test, examiners must always:**

- Read standard instructions to each applicant for each part of the test (a list of instructions is provided to the examiner for this purpose).
- Use only Department-approved forms and test procedures.
- Use only Department-approved off-street exercises and on-street driving test routes.

Any third-party testing organization or examiner who intentionally misrepresents a driving skills test by omitting any test requirement or participates in any illegal activity related to driver licensing is subject to severe penalties including loss of testing authorization, criminal prosecution and restitution for monetary damages to the test applicant and/or the Department.

A person (not limited to the examiner or driver applicant) who knowingly encourages, facilitates or participates in improper, illegal or fraudulent driving skills testing is subject to criminal prosecution.

Any person found to have been improperly, illegally or fraudulently tested must take the test(s) again. The third-party testing organization will be liable for the costs associated with retesting.

**Improper, fraudulent or unlawful driver's license tests result in illegal license applications.** Public Act 300 of 1949, also known as the Michigan Vehicle Code, includes the following concerning illegal driver testing.

- A person who makes a false certification regarding any driver license application is guilty of a felony.
- A person who bribes or attempts to corrupt a person or agency that conducts a driving skills test under an agreement entered into with the Secretary of State with the intent to influence the opinion or decision of the person or agency conducting the driving skills test is guilty of a felony.
- A designated examining officer appointed or designated by the Secretary of State who conducts a driving skills test under an agreement entered into with the Secretary of State and who varies from, shortens, or in any other way changes the method or examination criteria prescribed under that agreement is guilty of a felony.
- A person who forges, counterfeits, or alters a driving skills test certificate issued by a designated examining officer appointed or designated by the Secretary of State is guilty of a felony.

A felony committed under these laws shall be punished by imprisonment for not less than one year nor more than five years and fines up to \$5,000 for the first offense. Subsequent convictions result in additional penalties.

## **Third-Party Testing Organization Business Requirements**

Third-party testing organizations must adhere to certain business practices and administer driving skills tests according to established standards and procedures described in a formal, legal agreement with the Department. Among many contract requirements, third-party testing organizations must:

- Be approved by the Department before testing services are offered.
- Maintain an established place of business and obtain written permission to use a testing site.
- Respond to testing inquiries within one business day.
- Publish and make available a printed fee and refund policy.
- Provide a receipt for payment. Important note: fees are not regulated by the Department.
- Maintain a surety bond that provides for reimbursement if an applicant must be retested due to examiner misconduct.
- Ensure examiners conduct driving skills tests in compliance with department requirements.

## **Reporting Improper, Illegal or Fraudulent Testing Activities**

Improper, illegal or fraudulent testing activity should be reported immediately to the Michigan Department of State. Information needed includes the name(s) of the person(s) and organization(s) involved, the date(s) of the incident(s) and a detailed description of the activity observed or discussed. All legitimate reports will be investigated. A written statement may be required. This information should be submitted by mail, fax or e-mail to:

**Michigan Department of State  
Bureau of Regulatory Services  
Driver Programs Division  
Lansing, MI 48918  
Phone (517) 241-6850  
Fax (517) 373-0964  
ThirdPartyTesting@Michigan.gov**

## **Foreign Language Interpreters**

When a language barrier exists between an applicant and the examiner, the applicant is entitled to use an interpreter during the driving skills test. Exception: an interpreter may assist before and after a CDL skills test, but no assistance is allowed during the test. An applicant may bring a foreign language interpreter. A list of Department-approved foreign language interpreters is available at any Secretary of State office. The Department does not provide compensation to foreign language interpreters.

## **Interpreters for the Deaf and Hard of Hearing**

A deaf or hard of hearing individual may use a sign language interpreter during the driving skills test. The driver may know an interpreter or the Department of State can provide a list of interpreters. In either case, state compensation is available to the interpreter for services provided during the driving skills test. For a list of interpreters for the deaf or hard of hearing, contact the Department of State Information Center at 1-888-SOS-MICH (1-888-767-6424).

To be paid for services rendered during a driving skills test, interpreters for the deaf or hard of hearing should submit an invoice to the third-party testing organization. The organization will forward the information to the Department of State for processing. The invoice must include:

- Date, itemized cost and description of the service given.
- Name and driver license number of the applicant.
- Name (or business name), mailing address, and the Federal ID or Social Security number of the interpreter.

## **Facilitators**

A facilitator is a person who assists a driver license applicant in obtaining a driver license, and may provide language interpretation, offer driver training, schedule appointments or transport applicants to the test site. Michigan law requires that anyone who offers driver training for a fee must be licensed by the Department of State. A Michigan driver license can be obtained without the help of a facilitator.

At the test site, the interpreter and/or facilitator must present their photo driver license to the third party examiner. The examiner must record the interpreter or facilitator name and driver's license number on the applicant score sheet. If the facilitator/interpreter is unwilling to provide this information, the driving skills test will not be administered. All interpreters must be at least 16 years old.

During the test, the interpreter may only communicate with the driver to translate each set of instructions as the examiner gives them. Additional comments by the interpreter are not permitted except in an emergency. The examiner may terminate the driving skills test after giving one warning of unnecessary interaction with the driver.

## **Requirements for Taking the Driving Skills Test**

Applicants under age 18 must meet the following requirements **before** taking the driving skills test:

- Complete Segment 1 of an approved driver education course.
- Obtain a Michigan Level 1 license from a Secretary of State office and hold the Level 1 license for a minimum of 180 days prior to testing. Your driving skills test examiner must verify that you have held your Level 1 license for the required time.
- Complete Segment 2 of an approved public or private driver education program. You must present your Segment 2 completion certificate to your driving skills test examiner.
- Verify that you have logged a minimum of 50 hours of practice driving, 10 hours of which must have occurred at night, with a parent or legal guardian (or with the permission of the parent or legal guardian, any licensed driver at least age 21). See Appendix A for the Student Driving Experience Log.
- Be accompanied by a parent or legal guardian (or an adult appointed, in writing, by a parent or guardian).
- Be at least 15 years of age.
- Have no convictions, civil infractions, license suspensions or at-fault crashes during the 90-day period immediately preceding your driving skills test and application for your Level 2 license.

Applicants 18 years of age or older, not previously licensed in this state or in any other state or country, must meet the following requirements before taking a driving skills test:

- Pass required vision and knowledge (written) tests at a Michigan Secretary of State office.
- Pay required fees and obtain a Michigan Operator or Chauffeur Temporary Instruction Permit (TIP).
- Practice driving on a TIP for a minimum of 30 days to become eligible to take the driving skills test.

If you have been previously licensed in any state, and your license has been expired for more than four years, you will need to obtain a temporary instruction permit (TIP) and pass the required driving skills test. Your 30-day minimum practice period may be waived by Secretary of State branch office staff.

## **Scheduling a Driving Skills Test**

To take a driving skills test in Michigan, you must contact an approved third-party testing organization.

Third-party testing organizations may be listed in your local area telephone book. The Department of State provides a listing of organizations, available from the following sources:

- Internet: [www.Michigan.gov/sos](http://www.Michigan.gov/sos)
- Department of State Information Center:  
1-888-SOS-MICH (1-888-767-6424)
- Secretary of State offices

Fees charged by third-party testing organizations are **not regulated** by the Michigan Department of State. **Before** scheduling an appointment, applicants should inquire about all third-party testing fees, including initial and retest fees, refund policies, charges for improper documents, defective equipment, and failure to keep a test appointment.

## What to Take to the Third-Party Testing Organization

- If you are under 18 years of age, a valid Michigan Level 1 license that you have held for a minimum of 180 days, along with your Segment 2 Driver Education completion certificate.
- If you are 18 years of age or older, a valid Michigan temporary instruction permit that you held for at least 30 days. The 30-day practice period may be waived by Secretary of State branch office staff if you were previously licensed in Michigan, another state, or another country.
- If you are under age 18, your parent or legal guardian must verify that you have completed at least 50 hours of supervised driving, including a minimum of 10 hours at night, by signing the certification statement on your driving skills test score sheet. If your parent or legal guardian cannot attend your driving skills test, please use or copy the certification statement in Appendix A, have it signed and present it to the third-party examiner.
- If you are from another country, you must present your home country driver license and validated road test receipt from the Secretary of State.
- You must provide a vehicle that is in safe working order. The test vehicle should be one you are familiar with and have used during your practice driving.
- You must show proof of valid insurance, current vehicle registration and valid license plate for the test vehicle.
- Only the applicant, examiner, and any required passenger and/or interpreter may be in the vehicle. If the applicant is a minor, the minor's parent, legal guardian or authorized designated representative must be present throughout the test. Any designated representative must be authorized in writing by the parent or legal guardian. **No other passengers are allowed to be present during the test.**

## Tests Terminated Due to Defective Equipment

The following safety equipment guidelines will be used when administering the automobile driving skills test. Together, examiners and applicants will inspect and familiarize themselves with specific vehicle components. Certain defective vehicle equipment is reason for refusal of the driving skills test if it jeopardizes the safety of the vehicle's occupants.

## **Safety inspection includes the following equipment:**

Brakes

Brake lights

Center-mounted rear brake light on 1986 or newer models

Doors (\*)

Fuel level

Headlights

Heater/Defroster

Horn

Lug nuts (only one can be missing per vehicle)

Muffler

Rearview mirror and outside left mirror

Safety belts for all occupants

Seats for all occupants

Speedometer

Suspension components

Taillights

Tires (properly inflated; not damaged)

Turn signals (front and rear)

Windshield (\*\*)

Windshield wipers and washers

\* The driver and passenger doors must work from the inside and outside. Doors that cannot be opened are safety hazards.

\*\* Examiners may refuse to administer a test if the vehicle's windshield is cracked so that it obstructs the driver's view.

**When used for testing purposes, driver education vehicles must not display any warning signs used for training. This includes "Student Driver" identification signs.**

## **Other Automatic Failures**

- Disregarding instructions or refusal to perform instructed maneuver.
- Repeated failure to follow instructions will result in test termination. If you intentionally fail to follow an examiner's instructions, the examiner will give you a verbal warning and ask you to repeat the exercise. If you fail to follow the same instructions twice, the test will be terminated as an automatic

failure. If you do not understand the instructions the first time, the examiner will reread the instructions without penalty.

- Offering the examiner a bribe or gratuity.
- Refusal to wear a safety belt, unless you have a physician's statement or waiver.
- Any accident (may result in failure).
- Traffic violations or hazardous actions including, but not limited to:

Hazardous actions in which:

- Accident is prevented by others.
- Examiner prevents crash or illegal action (i.e., running a red light).
- Driving over curb or sidewalk, endangering others.
- Driver creates serious hazard for other traffic.
- Fails to yield (adversely affecting traffic/pedestrians).

Traffic violations in which the driver:

- Fails to yield right-of-way to a funeral procession.
- Passes a stopped school bus with its red lights flashing.
- Fails to properly respond when encountering an emergency vehicle.
- Turns left or right on red traffic light when prohibited by law.
- Makes a turn from the wrong lane.
- Passes improperly.
- Drives the wrong way on a one-way street.
- Drives on the wrong side of the street.
- Fails to stop for red light, flashing red light or stop sign.
- Fails to stop for railroad signal or drives around railroad gates.
- Speeds 4-9 mph over the basic speed limit (reasonable and prudent), or posted speed limit (white regulatory sign) after one warning.
- Speeds 10 mph or more over the basic speed limit (reasonable and prudent) or posted speed limit (white regulatory sign) with no warning necessary.
- Follows another vehicle too closely (after one warning).

### **Dangerously Inexperienced Drivers**

You must obtain a passing score and finish the driving skills test without committing an automatic failure listed above. In addition, an examiner may terminate a test if you exhibit any behavior that demonstrates you may be dangerously inexperienced. For example, a test will be terminated if you:

- Cannot maintain the minimum posted speed limit on the expressway (unless traffic or weather warrants lower speeds).
- Drive more than 10 mph under the regulatory speed limit after one warning (unless traffic or weather conditions warrant lower speeds).
- When operating a manual transmission vehicle, you are unable to shift gears properly or operate the vehicle safely.
- When driving an automatic transmission vehicle, you are unable to determine the proper gear for operating the vehicle safely.
- Stall the vehicle resulting in hazardous action or obstructing traffic.
- Lose control of the vehicle causing the examiner to take evasive action or assume control of the vehicle.

## Components of the Driving Skills Test

The driving skills test always includes a vehicle component familiarization and safety inspection (not scored) and two scored test segments. Each segment must be passed in sequence. **A failure of any part terminates testing.** On subsequent attempts, you must start over from the beginning (vehicle inspection, off-road skills test, then on-road driving test). You will be allowed only one attempt in a 24-hour period, unless the failure is due to faulty equipment or documents.

The test segments must always be given in the following order:

- Vehicle familiarization and safety inspection.
- Basic control skills test.
- On-road driving test.

## Basic Control Skills Test Requirements

The basic vehicle control skills test consists of a series of off-road exercises. Scoring will be based on the following standards:

**Encroachments:** You are penalized each time your vehicle touches an exercise boundary. **Each encroachment counts as an error.**

**Repositioning:** You will be penalized each time you reposition your vehicle to correct your path of travel. For example, in a backing

maneuver, a reposition point is assessed each time you adjust your vehicle forward. Likewise, in a forward maneuver, a reposition point is assessed each time you adjust your vehicle backwards. **Each reposition will count as an error.**

**Final position:** The examiner will assess how your vehicle finishes each exercise within the exercise boundaries.

At the end of the basic control skills exercises, the examiner will add your total cumulative points. To pass this segment and continue with the on-road driving test, you must complete the basic control skills test with **six errors or less.**

The three required exercises you must perform in the Basic Control Skills test are outlined below in figures 1-3.

### **Figure 1: Forward Stop Line**

You must drive forward and stop your vehicle with your front bumper within 2 feet of the last “stop line” without touching or going past the stop line. You may stop only once, and you may not lean out the window to see better. You will be scored on the final position of your vehicle relative to the stop line.

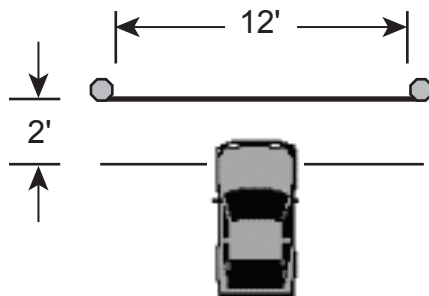

## Figure 2: Curved path backing - sight side (Y-turn) and right turn

You must back your vehicle from a 90-degree angle into a simulated driveway. Try to back into the space without touching or crossing over either side boundary (excluding mirrors). Try to finish the exercise with the rear bumper (farthest most point) of your vehicle within 2 feet of the rear boundary, not on or over the solid line between the cones. Once you have finished backing, you will drive forward and turn right out of the driveway. Try not to touch or cross over any side boundaries or hit any cones as you turn right exiting the driveway.

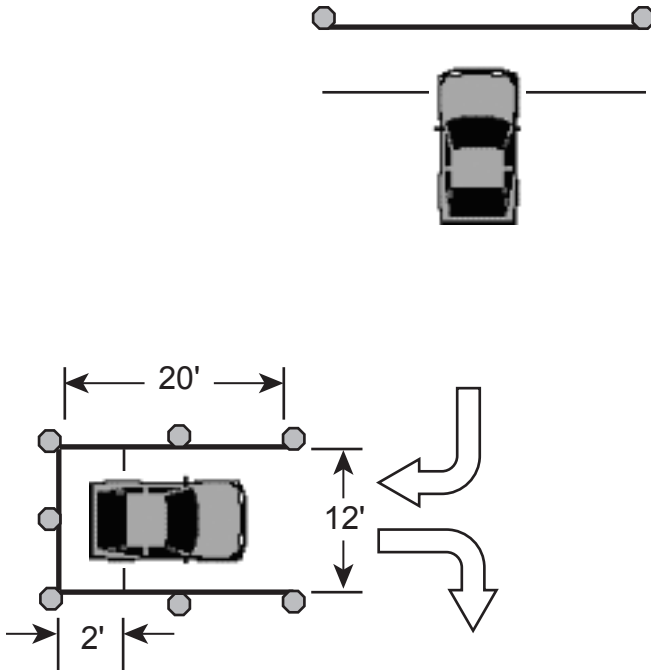

### Figure 3: Curved path backing - blind side (parallel parking)

You must drive by the entrance of a parking space located on the passenger side of your vehicle. You will then back your vehicle into the space. The size of the space is determined by adding 6 feet to the length of your vehicle. You must try to finish the exercise with your vehicle positioned completely within the parking space. Your vehicle does **not** have to be evenly centered within the front and back boundary lines. When backing, try to perform the maneuver without touching or crossing over any boundary lines or repositioning your vehicle.

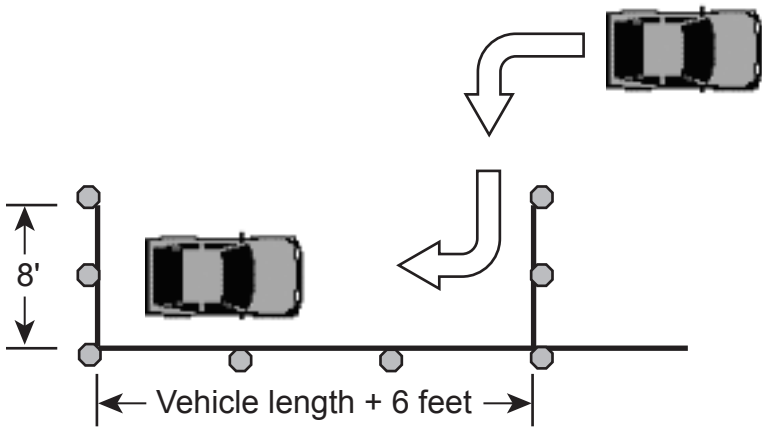

### The On-the-Road Test

You must demonstrate your ability to drive safely over a predetermined route. The route will contain a variety of traffic situations including city, residential and expressway driving. At all times during the driving test, you must operate your vehicle in a safe and responsible manner, obeying all traffic laws.

The examiner will observe and score you on specific maneuvers as well as on your general driving behavior. You are expected to drive straight ahead unless given instructions to turn or perform other maneuvers. The examiner will give you directions for each maneuver as far in advance as possible and will not ask you to do anything illegal or unsafe.

## Driving Skills Test Requirements

Although every driving test route may not be identical, each route will contain similar maneuvers that will “equalize” the difficulty of any route approved by the Michigan Department of State. Every route will attempt to contain each of the following maneuvers:

- Left turns with varying difficulty.
- Right turns with varying difficulty.
- Intersections that involve stopping and then driving straight through.
- Intersections that involve driving straight through without stopping.
- Expressway or rural highway driving (lane changes required).
- Urban and residential driving (lane changes required).
- Collision avoidance (simulated head-on collision).
- Curve.
- Railroad crossing (actual or simulated).
- Turning a fan (or radio) on and off while driving.

## Driving Skills Test Scoring Standards

The proper way to perform each of the required driving test maneuvers are outlined in this section. To better prepare yourself for your test, please read this section carefully and practice these maneuvers until you have mastered them. The information provided in this section contains scoring tips and should not be considered comprehensive instructions on how to complete the maneuvers.

To obtain a passing score, you must not accumulate **more than 25 points** or receive an automatic failure.

### Turns:

You have been asked to make a turn. Be sure to:

- Recognize the need to set up for the turn in advance; move to the appropriate lane in preparation for the upcoming turn.
- Enter the turn lane at a designated opening (if traffic permits). Do not enter too early or too late and do not straddle or cross over lane markings.
- Check traffic in all directions. Traffic checks must be made obvious to the examiner by moving your head.

- Check blind spots by looking over your shoulder before merging into the curb lane or center left turn lane.
- Use turn signals and safely move into the appropriate turn lane.
- Enter left or right turn lanes at their designated openings.
- Activate your turn signal approximately 100 feet ahead of a turn, but not so early as to mislead others about where you are turning.
- Brake smoothly without jerking the vehicle. Never depress the accelerator and brake pedal at the same time.

If you must stop before making the turn:

- Yield to traffic or pedestrians in an intersection. Do not stop unnecessarily for yield signs, flashing yellow lights, green traffic signals, etc.
- Come to a smooth, complete stop without skidding. Do not let your vehicle roll forward or backward while stopped.
- Come to a complete stop before the stop line, crosswalk, or sidewalk. If there is no stop line, crosswalk, or sidewalk, stop at a safe place before the intersection.
- If stopping behind another vehicle, stop at a safe distance where you can see, at a minimum, the rear tires on the vehicle directly ahead of you (safe gap). Always leave enough space to pull out and around the vehicle in front of you should it be necessary (escape route).
- On left turns, if appropriate and when safe to do so, pull ahead into the intersection to prepare for your turn. If present, keep the traffic signal visible and keep your front wheels aimed straight ahead until starting your turn.

When ready to turn:

- Check traffic in all directions, making your search obvious to the examiner by moving your head. Make sure you have enough time to make the turn safely without causing other vehicles to adjust their speed or take evasive action (proper timing).
- Yield to any vehicles or pedestrians in the intersection.
- Unless shifting, you should keep both hands on the steering wheel during the turn. Do not palm the wheel.

- When turning, do not allow your vehicle to touch or cross lane lines or hit curbs.
- Your turn should be completed smoothly, at a speed that is not too fast or too slow.

Upon completing the turn:

- Check traffic in all directions, making your search obvious to the examiner by moving your head.
- Turn into the correct lane. When turning *left* from a single left turn lane, your vehicle should finish the turn in the lane that is directly to the right of the centerline. When turning *right*, your vehicle should finish the turn in the right-most (curb) lane.
- Maintain controlled steering to straighten your vehicle after turning.
- Accelerate to adjust your vehicle speed and keep pace with the flow of traffic.
- Signal and move to the right lane if you are traveling slower than other traffic, or if other vehicles are passing you on the right.

### **Stop intersections:**

As you approach an intersection that requires stopping prior to proceeding straight through:

- Check traffic in all directions, making your search obvious to the examiner by moving your head.
- Brake smoothly and stop without skidding or jerking the vehicle. Come to a full and complete stop. Do not let your vehicle roll forward or backward while stopped.
- Come to a complete stop before the stop line, crosswalk, or sidewalk. If there is no stop line, crosswalk, or sidewalk, stop at a safe place before the intersection.
- If stopping behind another vehicle, stop at a safe distance where you can see, at a minimum, the rear tires on the vehicle directly ahead of you (safe gap). Always leave enough space to pull out and around the vehicle in front of you should it be necessary (escape route).

As you drive through the intersection:

- Check traffic thoroughly in all directions, making your search obvious to the examiner by moving your head. Make sure you have enough time to cross the intersection safely without causing other vehicles to adjust their speed or take evasive action.
- If the traffic light turns yellow as you approach, you should attempt to stop before entering the intersection. If you cannot stop safely, do not speed up; drive cautiously through the intersection.
- Yield to any pedestrians or vehicles in the intersection.
- Do not change lanes in the middle of an intersection.
- Both hands should be kept on the steering wheel (unless shifting).
- Adjust your vehicle speed to keep pace with traffic.

### **Through intersections (do not require stopping):**

When approaching an intersection that does not require stopping:

- Check traffic in all directions, making your search obvious to the examiner by moving your head.
- Yield to any vehicles and pedestrians in the intersection. Unless you are yielding to vehicles or pedestrians, do not stop for green traffic lights. Unnecessary stopping can create a potentially dangerous situation.
- Take your foot off the accelerator as you scan the intersection for possible hazards. Placing your foot over the brake pedal while scanning helps you react quicker to potentially hazardous situations
- Do not change lanes in an intersection.
- Unless shifting, you should keep both hands on the steering wheel.
- Adjust your vehicle speed to keep pace with traffic.

### **Expressway or rural highway:**

Before entering an expressway:

- Check traffic to find an opening to merge into. Check blind spots by looking over your shoulder before merging onto the expressway.
- Activate your turn signal.

- Adjust your speed to allow you to merge into the flow of traffic.
- Merge smoothly into the nearest expressway lane, allowing proper spacing between you and the vehicles in front of and behind you.
- Stay within lane markings.
- Cancel your turn signal once you have merged completely into the lane.

When driving on an expressway or on a rural highway:

- Check traffic regularly (usually at least once every 8-10 seconds). Make your traffic check obvious to the examiner by moving your head. Maintain awareness of merging and exiting vehicles. Also, look at least 12 seconds ahead of the vehicle to anticipate hazards.
- Maintain a “cushion of space” around your vehicle. Do not crowd other vehicles and avoid driving in a pack of vehicles.
- Select a safe and legal speed that allows you to keep up with the traffic flow without exceeding the speed limit or driving slower than the minimum posted speed, unless road and weather conditions determine otherwise.
- Drive in the right-most lane(s) unless you are passing another vehicle.
- Center your vehicle within the lane markings. Do not weave over lane lines.

When changing lanes on an expressway or on a rural highway:

- Drive at a speed approaching the flow of traffic to ensure a safe lane change.
- Check traffic in all directions. Check blind spots by looking over your shoulder before changing lanes.
- Activate your turn signal to alert other drivers that you intend to change lanes.
- Yield to any vehicles occupying the lane you are merging into.
- Merge smoothly into the next lane; keep your vehicle under control and maintain speed.
- Allow proper spacing between you and the vehicles in front of and behind you.
- Cancel your turn signal after completely merging into the lane.

When exiting an expressway:

- Check traffic in all directions, especially to the right, including looking over your shoulder to check your blind spot.
- Activate your turn signal to alert other drivers that you intend to exit.
- Exit at a speed appropriate for traffic conditions. Under normal conditions, your vehicle's speed should not drop below the posted minimum speed while on the expressway.
- Merge smoothly into the deceleration lane without driving over solid lane lines. Remain centered in your lane.
- Allow proper spacing between you and the vehicles around you.
- Once you are on the deceleration ramp, reduce your speed.
- Cancel your turn signal after you have merged completely into the deceleration lane.

### **Urban and residential areas:**

When driving in an urban or residential area:

- Check regularly (at least once every 5-7 seconds) for pedestrians, bicycles and moving or parked vehicles, especially in areas where children may be present. Make your traffic checks obvious to the examiner by moving your head.
- Maintain a "cushion of space" around your vehicle. Do not crowd other vehicles and avoid driving in a pack of vehicles.
- Select a safe, reasonable and prudent speed that allows you to keep up with the traffic flow without exceeding the speed limit.
- When traveling in a multi-lane urban area, you should remain in the right lane if you are traveling slower than other traffic.
- Keep your vehicle centered in your lane. Do not weave outside of lane markings or into the lane of oncoming traffic.

When changing lanes in an urban area:

- Check traffic in all directions. Check blind spots by looking over your shoulder before changing lanes.
- Activate your turn signal to alert other drivers that you intend to change lanes.

- Yield to any vehicles occupying the lane you are merging into.
- Merge smoothly into the next lane; keep your vehicle under control and maintain speed.
- Allow proper spacing between you and the vehicles around you.
- Cancel your turn signal after merging completely into the lane.

### **Curves:**

When approaching a curve:

- Check traffic thoroughly in all directions. Keep your head up and remain focused ahead of the curve.
- **Before** entering the curve, reduce speed so further braking or shifting is not required in the curve.
- Keep both hands on the steering wheel.
- Maintain a safe and legal speed driving **through** the curve.
- Keep the vehicle within lane markings.

### **Railroad crossings:**

As you approach a railroad crossing:

- Check traffic in all directions making your search obvious to the examiner by moving your head.
- Look to the left and right by moving your head and listen for the presence of trains.
- Decelerate, brake smoothly and shift gears before you cross the railroad tracks. Shifting gears while crossing the railroad tracks is not safe. Your speed over the tracks should be appropriate for the condition of the tracks and road surface.
- Keep both hands on the steering wheel while driving over the railroad tracks.
- Do not change lanes as you cross the railroad tracks.
- If required to stop for a train, remain stopped behind the stop line until it is safe and legal for you to proceed.

### **Turn fan (or radio) on/off:**

When the examiner instructs you to turn on/off your fan (or radio):

- If you must take your eyes off the road to locate your fan (or radio) switch, do so briefly. Taking your eyes off the road for long periods of time may create a hazardous situation.
- Maintain your lane position and speed during this exercise.
- Removing your hand from the steering wheel to turn a fan (or radio) on or off should not cause you to weave out of your traffic lane.

### **Crash avoidance (simulated head-on collision):**

At a designated location, the examiner will ask you to verbalize what you would do if an oncoming vehicle were headed directly at you in your lane. During this exercise, you will be required to **verbalize, not demonstrate**, the following concepts. Try to maintain the speed of your vehicle while verbalizing this exercise.

- To avoid a head-on collision, drive off the road to the right.
- If the oncoming vehicle forces you to hit a fixed object on the side of the road, you should choose a soft object, not a hard object, if possible. You should also try to hit the object with a glancing blow (side-swipe).

## **General Driving Habits**

During the test, you must:

- Wear your safety belt (all occupants in vehicle must wear safety belts).
- Obey all traffic signs, signals and laws.
- Complete all traffic checks by moving your head to make your search obvious to the examiner.
- Keep both hands on the steering wheel (unless shifting).
- Complete the test without an accident or moving violation.

Throughout the test, you will be scored on your overall performance in the following general driving behavior categories:

**Search:**

- Establish a pattern of searching left, right, ahead, and behind using all available mirrors and moving your head to make your traffic checks obvious to the examiner. Searching involves head and eye movements, as well as turning and looking over your shoulder to check blind spots.
- Anticipate traffic, pedestrians, people entering and exiting parked vehicles and potentially hazardous situations well in advance. Pay careful attention to merging vehicles and vehicles near driveways and intersections.
- Scan ahead to get the “big picture.” Keep your eyes and head up to observe well ahead of the vehicle (about 12 seconds).
- Unless you are yielding to traffic or pedestrians in an intersection, do not stop for green traffic lights. Doing so can create a potentially dangerous situation.
- When driving, keep distracting behaviors to a minimum. Your attention should remain focused on driving tasks and not on distractions that may prevent you from spotting potential hazards.

**Speed and brake control:**

- Do not exceed the speed limit that is prescribed by a regulatory (white) sign, advisory (yellow) sign or by prevailing weather, roadway and traffic conditions.
- Do not drive too slowly or too fast for traffic conditions. Try to keep pace with the surrounding traffic without exceeding the speed limit. This is especially important when turning or driving through a curve.
- Accelerate evenly and smoothly without jerking the vehicle.
- When decelerating, brake smoothly and evenly, not too hard or too soft. Under normal circumstances, you should not ride or pump the brakes.
- Always come to a complete stop. Do not roll through stops or allow the vehicle to drift forward or backward at stops.

- When driving a standard transmission vehicle, do not clash gears, rev or lug the engine. Also, know how to use the clutch properly to prevent choppy accelerating and decelerating.
- Make sure you are in a gear that is appropriate for the direction and speed you are traveling.
- Change gears smoothly and as needed, but do not coast to a stop with the gearshift lever in neutral. Once stopped, you may place the transmission in neutral.
- Check your speedometer occasionally to make sure you are traveling at a safe and legal speed but be careful not to look at your speedometer too frequently. Overly frequent checks of your speedometer may cause you to take your eyes off the road too often.

### **Direction and space control:**

- Whenever you change lanes or turn, you must use your turn signal. Once you complete a lane change, you must also remember to cancel your signal if it does not automatically cancel.
- When turning, do not touch or cross over your lane markings or hit curbs.
- When driving straight ahead, try to keep your vehicle centered within your lane without weaving outside of the lane markings.
- Do not turn from or into the incorrect lane.
- When driving on an expressway, in a multi-lane urban area or on a rural highway, move to the right lane if you are traveling slower than other traffic, or if vehicles are passing you on the right.
- When necessary, come to a complete stop behind stop lines, crosswalks, sidewalks, or at a safe place before entering an intersection (behind a stop sign, if practical). If an object is obstructing your vision, you may, after stopping behind a stop line, crosswalk, etc., roll forward and stop again as long as you stop before entering the intersection.
- When stopped behind other vehicles, you must be able to see, at a minimum, the rear tires of the vehicle ahead of you (safe gap). Always leave enough space to pull out and around the vehicle in front of you should it be necessary (escape route).

- Maintain a reasonable space cushion between you and other vehicles. Do not crowd other vehicles or allow other vehicles to crowd you. Keeping a safe distance between your vehicle and other vehicles will give you more time to react to hazardous situations.
- When merging with other traffic, be sure you maintain proper spacing in front and in back of your vehicle.

### **Steering control:**

- Don't palm the wheel or drive with only one hand on the wheel. Although you may have to remove a hand to adjust driver controls, try not to do so while driving through an intersection, turning, or changing lanes.
- At all times during the skills tests, you must maintain proper control of your vehicle. Your ability to steer smoothly, recover easily from turns and control your vehicle within lane markings will be monitored carefully.
- When pausing to make a left turn, keep the front wheels of your vehicle pointed straight ahead until you begin your turn. If you stop with your wheels turned left, a rear end collision will likely send you into oncoming traffic.

### **Timing:**

- When stopping, do not brake too early or too late. Late braking can result in vehicle skidding or passengers being thrust forward in their seat.
- Activate your turn signal at least 100 feet ahead of where you are turning (approximately 3-4 seconds), but not so early as to mislead others as to where you are turning.
- Do not drive too timidly or aggressively. Overly timid driving may indicate a lack of necessary experience and skill, and overly aggressive driving may stretch you beyond your ability to handle your vehicle safely.
- Make sure you have enough time to complete any maneuver safely without causing other vehicles to adjust their speed or take evasive action. Your timing and ability to adjust your speed to match traffic conditions is very important.

- Always yield to other traffic or pedestrians in your path of travel. When you see a potentially hazardous situation, take action in advance to avoid making the situation more hazardous.

### **Miscellaneous traffic violations:**

Told to wear seat belt: Unless you have a physician's statement or waiver, a seat belt must be worn during the driving test. Refusal will result in an automatic failure.

Fails to respond to stationary emergency vehicle: You are required by law to exhibit due care and caution (lane change or reduce speed as traffic/roadway permits) when approaching a stationary emergency vehicle.

Other: When the vehicle is in motion, you must obey all traffic laws.

### **Completion of the Driving Skills Test**

Once you have completed your driving skills test, the examiner will review your results and give you feedback on your driving performance. If you do not successfully complete your test, you may reschedule a subsequent test after 24 hours. Tests terminated due to driver performance **cannot** be rescheduled for the same day.

If you successfully complete your driving skills test, the examiner will issue a skills test certificate. You and the examiner must both sign the certificate showing that you received a complete and valid test.

The skills test certificate is **not** a license. You must take your skills test certificate to a Secretary of State office to receive your full driving privileges. The skills test certificate is valid for 60 days after it is issued. Certificates issued to teens under the age of 16 are valid for 60 days after their 16th birthday.

Appendix A

**STUDENT DRIVING EXPERIENCE LOG**

Keep a record of your teenager's driving experience

Student name: \_\_\_\_\_

Date	Miles	Daytime Hours	Nighttime Hours	Type of Driving Experience





**Secretary of State**  
**Terri Lynn Land**

[www.Michigan.gov/sos](http://www.Michigan.gov/sos)

An alternative format of this printed material may be obtained by contacting the  
Department of State (888) SOS-MICH (767-6424).

SOS-360 revised 4/2010

150,000; \$9,634; \$0.064 each

Printed by Authority of P.A. 300 of 1949.